

Rapid 5050e/5080e



SE Bruksanvisning

Läs och förstå bruksanvisningen innan apparaten används.

DK Brugervejledning

Læs brugervejledningen nøje igennem, inden du bruger apparatet.

SF Käyttöohje

Lue käyttöohje ja ymmärrä sen sisältö ennen kuin alat käyttää konetta.

DE Bedienungsanleitung

Lesen Sie die Bedienungsanleitung sorgfältig durch und machen Sie sich mit dem Inhalt vertraut, bevor Sie die Maschine benutzen.

NL Gebruiksaanwijzing

Lees de gebruiksaanwijzing grondig door en vergewis u ervan dat u ze begrijpt voor u het apparaat in gebruik neemt.

GB Operator's manual

Read these instructions carefully and make sure you understand them before using the machine.

FR Manuel d' utilisation

Lire attentivement et bien assimiler le manuel d' utilisation avant de se servir de la machine.

ES Manual para el usuario

Lea estas instrucciones minuciosamente y asegúrese de comprenderlas antes de usar la grapadora.

PT Manual do utilizador

Leia e compreenda o manual do utilizador antes de pôr o aparelho em funcionamento.

IT Istruzioni per l'uso

Prima di usare la cucitrice, leggere attentamente queste istruzioni per l'uso e comprenderne il contenuto.

GR Οδηγίες χρήσεως

Μελετήστε και κατανοείστε τις οδηγίες χρήσεως πριν χρησιμοποιήσετε το μηχάνημα.

PL Instrukcja obsługi –

Zapoznaj się z nią przed uruchomieniem maszyny”

RU Инструкция

Перед использованием аппаратом, прочитайте и изучите инструкцию.

SE	SVENSKA	1
DK	DANSK.....	7
SF	SUOMI	13
DE	DEUTSCH.....	19
NL	NEDERLANDS	25
GB	ENGLISH	31
FR	FRANÇAIS	37
ES	ESPAÑOL	43
PT	PORTUGUÊS	49
IT	ITALIANO	55
GR	ΕΛΛΗΝΙΚΑ	61
PL	POLSKI	67
RU	РУССКИЙ.....	73



Rapid ®

A



B

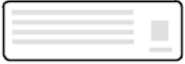

C



D

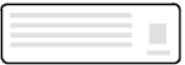

Fig. 1



Fig. 2

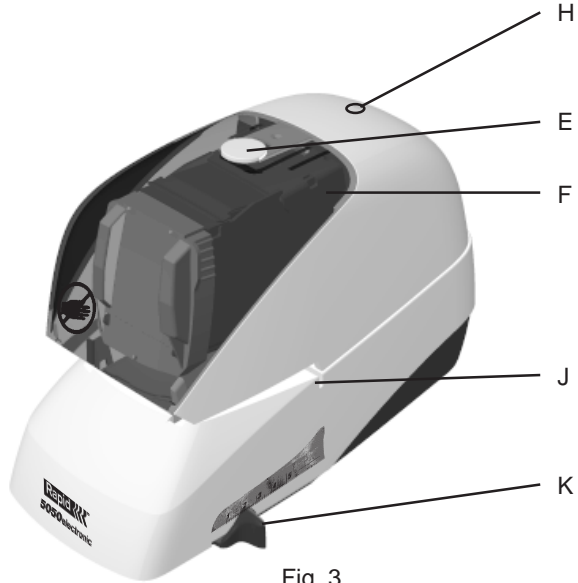

Fig. 3



Fig. 4

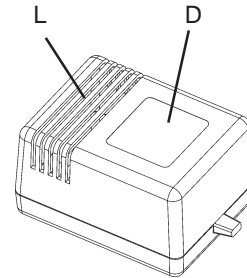

Fig. 6

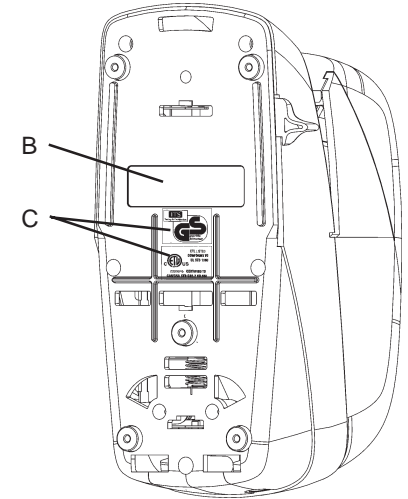

Fig. 5

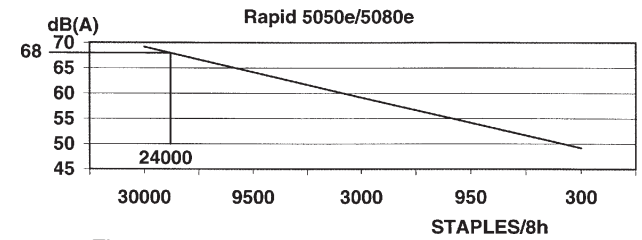

Fig. 7

INTRODUCTION

This Operator's Manual describes the Rapid 5050e and 5080e.

Read the operator's manual carefully before using the machine.

The manual contains safety regulations and descriptions of checks on parts which are critical for safety, together with directions for the correct use and maintenance of the machine. The figures can be found on the cover fold-out.

SAFETY REGULATIONS

- The machine may only be used by personnel with knowledge of the safety regulations and correct handling as described in this manual.
- The machine must only be used with the supplied adapter, Rapid 5050e/5080e, only.
- The visor must be mounted at the machine when stapling.
- Only the papers (or other objects) to be stapled should be put into position under the visor.
- It must not be possible to staple without the visor mounted. Check on this every day as described in the section "Checking safety functions".
- The machine must be turned off before it is moved.
- The machine must be connected to an electric socket which has a protective earth.
- The machine must not be subjected to moisture. It must not be located in a position where rain or splashes of water can fall on it.
- Repairs and other measures, besides those described in this manual, must be carried out by service personnel authorised by Isaberg AB, its companies or agents.
- Repair of faults or damage to the machine or its electrical connection must be carried out by authorised service personnel.

SYMBOLS

Symbols in this manual



Read the operator's manual carefully and make sure you understand it properly before using the machine.



Warning text. Information critical for safety follows after this symbol.

Symbols on the machine

See figure 1.

- A Forbidden to put fingers underneath the visor.
- B Rating plate with the following data:
 - Manufacturer.
 - Type designation of machine.
 - Serial number.
 - Adapter.
 - Max. number of staples per minute.
 - Marking for type approval.
 - CE mark for compliance according to EU Directive (This mark will be found on machines sold in certain countries).
 - Year of manufacture.
- C The machine has been tested and approved by ETL and GS. (This mark will be found on machines sold in certain countries).

Symbols on the adapter

See figure 1.

- D Rating plate with the following data:
 - Manufacturer.
 - Type designation.
 - Electrical data.
 - Marking for type approval.
 - CE mark for compliance according to EU Directive (This mark will be found on machines sold in certain countries).
 - Year of manufacture.

DESCRIPTION

The Rapid 5050e/5080e is an electrically powered desktop stapler. Stapling is automatic when the object to be stapled is pushed into position under the visor.

The parts of the machine are shown in figure 2.

- | | |
|-----------------------|--|
| A Warning decal | H Low staples warning light |
| B Data plate | J Mounting groove for table |
| C ETL/GS-marking | K Lever for adjusting the staple depth |
| D Data plate, adapter | L Adapter |
| E Locking knob, visor | M Connection for pedal trigger |
| F Visor | N Connection for adapter |
| G Cassette | |

ACCESSORIES

Pedal intended for triggering the stapling. When the pedal is connected, the internal trigger is disabled.

Support table for the object to be stapled.

INSTALLATION

The Rapid 5050e/5080e is installed as follows:

- 1 Position the machine on a stable horizontal surface. The machine shall be placed on a smooth and clean surface so that the feet are fixed to the surface.
- 2 Check that the machine is suitable for the electrical power supply available (voltage and frequency) by reading the data on the rating plate (D). The machine must only be used with the supplied adapter, Rapid 5050e/5080e.
- 3 Insert the adapter's plug into the electric supply and the low voltage socket (N) to the machine.

OPERATION

Replacing the staple cassette

When only 19 staples are remaining in the cassette, the warning light (H) changes from green to red. Replace the staple cassette (G) as follows.

See fig. 2 and 3:

Fill the machine with staples when required as shown in figure 3:

- 1 Press the visor (F) locking knob (E) and remove the visor.
- 2 Hold the cassette in its upper part and pull it straight horizontally outwards.
- 3 Mount a new cassette in the opposite order.
- 4 Mount the visor. Check that its front part is correct positioned and that the locking knob snaps up.
- 5 The warning light shows green and the stapling can start.

Adjusting the trigger position

See fig. 3

The distance between the staple and the edge of the stapling object is determined by adjusting the staple depth with the lever (K). The distance is read at the scale above the lever.

Note that corner stapling and edge stapling can require different positions.

Stapling

Stapling is performed as follows:

- 1 Check that the lever (K) is adjusted for the correct stapling depth.
- 2 Connect the machine to the electrical supply. The warning light (H) will show green.



Warning: Only the stapling object is allowed to be placed under the visor.

- 3 Move the stapling object forward to the stapling position so that the trigger is pushed in.
- 4 Disconnect the machine from the electrical supply when the stapling is performed.

MAINTENANCE

Checking safety functions

One of the safety checks that should be done every day before the machine is used is to check on the visor's safety function.

Check the visor's safety switch as follows:

- 1 Connect the machine to the electrical supply.
- 2 Remove the visor by pressing its knob.
- 3 Test whether or not the machine will staple a piece of paper with the visor removed.

If the machine operates without the visor it must be disconnected immediately and sent for repair.

Cleaning

The machine should be cleaned when required as follows:

- 1 Remove the adapter by disconnecting its cables..
- 2 Clean the machine as required by blowing away dust and paper remnants.
- 3 If the machine is heavily soiled it should be cleaned with a moist rag.
- 4 If there are loose staples in the machine, lift it up and turn it in different positions when shaking it. The staples will fall out through the holes in the bottom of the machine.

TROUBLE SHOOTING

Staples not bent sufficiently

If the staple is insufficient bent or is folded over the object to be stapled, the following faults can have arisen:

- Stapling object too thick. At least 3 mm of the staple legs must penetrate through the object to ensure satisfactory results.
- Stapling object is too hard.
- Always use the correct original Rapid staple cassette.
- Loose staple in the mechanism. Send the machine for service.

Stapling movement is triggered but the machine does not staple

- The cassette is empty. The warning light shows red. Replace the cassette according to the instructions.
- A staple has stuck in the mechanism. Replace the cassette or remove carefully the defect staple. In the last case, cut the staple tape with a sharp knife or similar. Remove the cut staples and feed the staple band forward.
- Always use the correct original Rapid staple cassette with the correct marking.
- The cassette is damaged or worn. Replace the cassette according to the instructions.

Stapling movement not triggered

- No power supply.
Check that the adapter is connected to the machine and to the electrical supply.
Check that the on-off warning light shows steady green.
Check that there is voltage at the electric socket (a fuse may have blown).
- Check that the trigger springs back again when stapling.
- The machine is damaged. Send it away for service.
- The warning light is flashing, green or red. Send the machine away for service.

Measures at interrupted stapling cycle

A stapling cycle can be interrupted due to different reasons, e.g. power-failure or a plug has been removed. An interrupted stapling cycle is measured as follows:

1. Check that the machine is connected to the power supply. E.g. reconnect the plug if it has been removed.
2. Remove the visor by pressing its knob and pull it outwards.
3. Remove the cassette.
4. Remove the object to be stapled.
5. Mount a new cassette.

Note! The defect cassette can be repaired by service personnel.

TECHNICAL SPECIFICATION

Complete designation	Rapid 5050e	Rapid 5080e
Width	120 mm	120 mm
Length	245 mm	245 mm
Height	157 mm	160 mm
Weight	2,2 kg	2,2 kg
Max. capacity (80g copying paper)	50 sheets	80 sheets
Max. stapling depth	50 mm	50 mm
Staple cassette type	See the front of the cassette	
No. of staples in the cassette	5000	5000
Adapter:	Rapid 5050e/5080e	
Power/Current, adapter	See the data plate of the adapter	

When stapling at maximum frequency, 50 staples/min (24000 staples/8h, example in fig. 7), the equivalent noise level is 68 db(A).

Noise measurements carried out according to ISO 7779 with supplementary proposal "Electrical staplers: Noise test code".

A maximum 70 dB(A) equivalent noise level is a requirement in Germany in general premises of such as, shops, airport check-in areas, receptions, and similar.

ISABERG RAPID AB
Box 115
S-330 27 HESTRA
SWEDEN
