

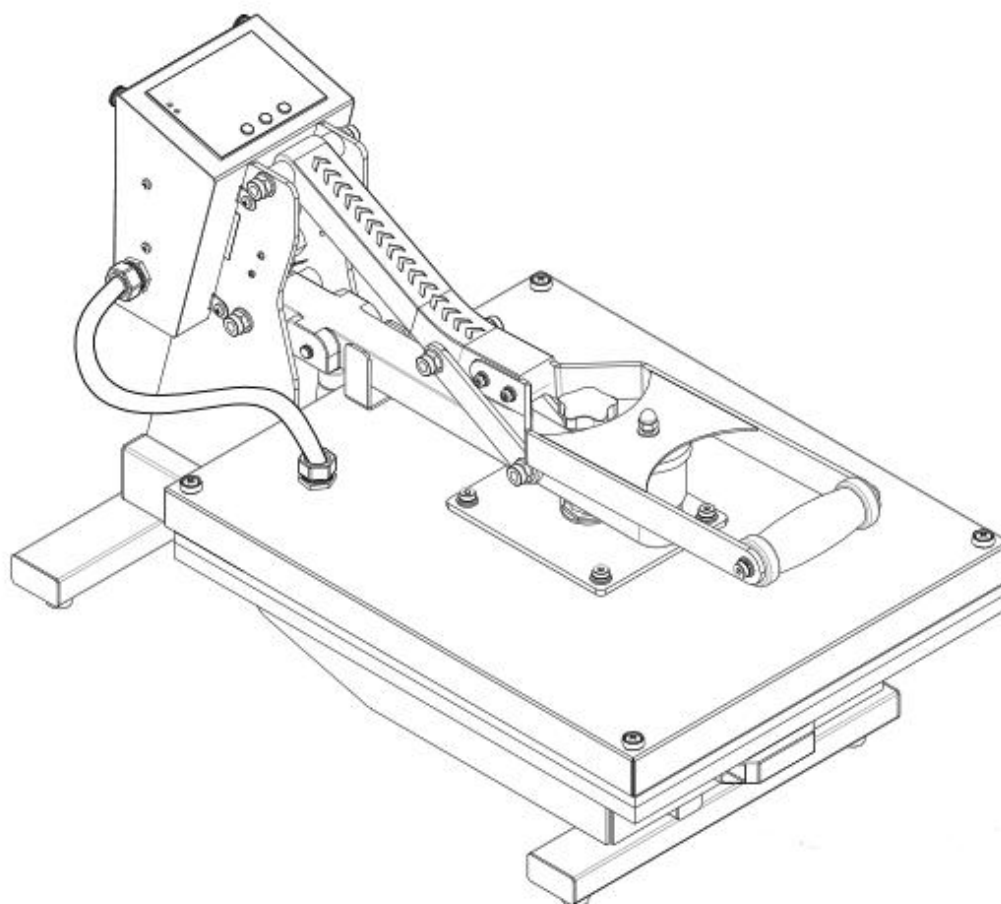

arkipLOT.com

ArkiPress_HP7/HP8E

Model. No.: UHP-15/20MS



CONTENTS

I. Assembly Drawing	2
II. Technical Parameters	2
III. Operation Process	3-4
IV. Maintenance	5
V. Trouble Shooting For Transfer Print Quality	5
VI. Circuit Diagram	6
VII. Explosion View	7-8



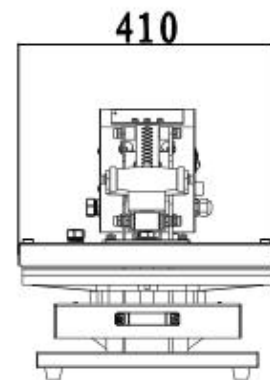
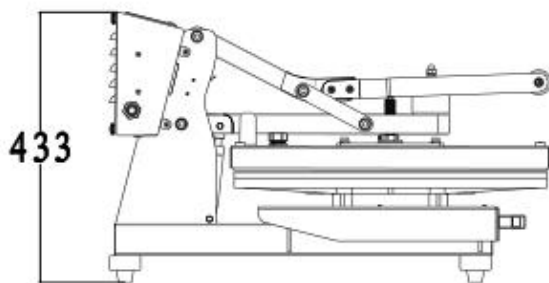
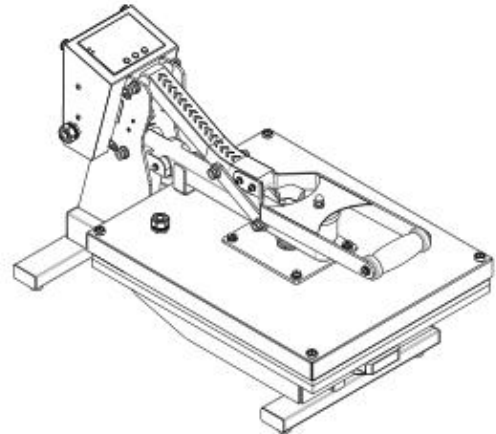
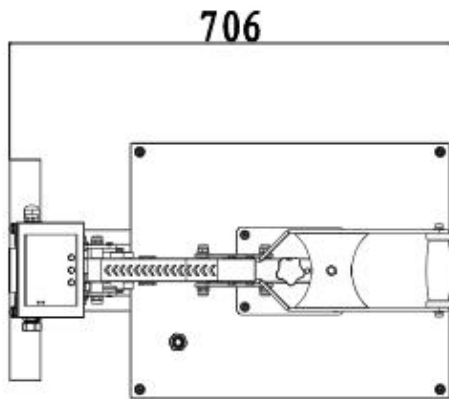





I. Assembly Drawing

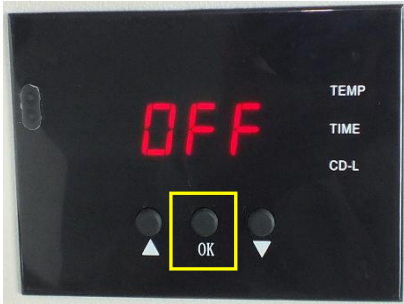

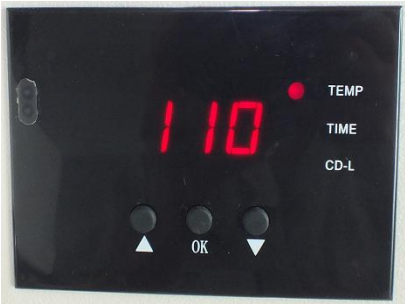







II. Technical Parameters

1. Model No.: UHP-15/20MS
2. Machine Dimensions: 706*410*433mm
3. Heat Platen Size: 38x38cm/ 40x50cm
4. Printable Articles Max Size: 400*500*10mm
5. Voltage: 220V/1 Phase; 120V/1 Phase
6. Power: 220V/1.8KW; 110V/1.6KW
7. Recommend Setting: 30~280s; 180~210°C.
Time Range: 0~999s
Maximum Temp: 225°C

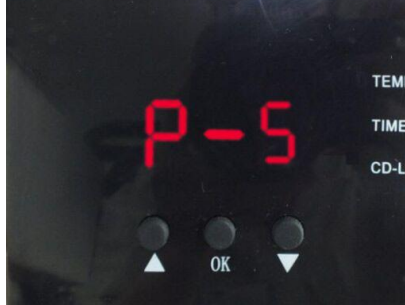
III. Operating Process

		
<p>Turn on power switch, temperature light is ON. The digital display shows .</p>	<p>Press  button, the  light is on (C denotes Celsius). Press arrows “△” or “▽” to select “C” or “F” (F denotes Fahrenheit) according to your habits.</p>	<p>Press  button, the temp  light is ON. Press Up “△” or Down “▽” button to set temperature according to different transfer material. (Normally 180°C~200°C) Note: Temperature will be shown on the controller only after it reached to 100°C, it's normal that there is no temperature shows right after the setting.</p>

2. Set time required

		
<p>Press  button after the temperature setting and the  time light is ON. Press Up “△” or Down “▽” button to set time according to different transfer material.</p>	<p>Press  button after time setting; the display shows the temperature starts to rise. “CD-L” shows the time counting down during your transfer.</p>	<p>If there is a difference between the actual temperature and temperature shows on the controller, you can use P5 mode to calibrate the difference. For example, when actual heat platen temperature is 180 °C but the display shows 200°C, press  button for 5 seconds to enter the P5 mode. When enter P5 mode, press UP button “△” to set to -20, and then press  button again for 5 seconds return to operation mode. In the contrast, when actual heat platen temperature is 200 °C but the display shows 180°C, press</p>

		Down button “▽” to set to +20, and then press  button 5 seconds return to operation mode
--	--	---

3. Printing methods

- Step 1: Make sure the cord is connected well to the wall socket. Lift up the handle to open the press. The press should always be in the open position when the press is heating. Place the object (i.e. T-shirt , Mouse Pad etc) and transfer paper with images facing down the object on under plate; adjust the pressure to be moderate and switch on the press.
- Step 2: Temperature indicator light is on. Set the temperature according to different transfer material. Recommended temperature is 180°C~200°C
- Step 3: Then set the time according to different transfer material.
- Step 4: When the temperature rise to the set temperature, the buzzer sends out sounds; then close down heat platen (meantime the sounds stop) and starts to transfer.
- Step 5: Time is counting down; once time is up, the buzzer will send out a sound again, then open up the heat platen (meantime the sounds stop).
- Step 6: Work finish and take out the object. If you want to print on another object, place the object on press bed and confirm the TIME and TEMPERATURE set as last time, then repeat above process. Unplug the power cord when is machine is not in use.
- Step 7: Consult the Transfer Paper instructions on whether to peel cold or hot, Here are suggested Pressing time guidelines for different transfer paper.
- Ink-Jet Transfer Paper (fabric) 14-18 seconds
 Laser Copier/Printer Transfer Paper (fabric) 18-25 seconds
 Sublimation Transfers (onto Fabrics) 25-30 seconds
 Sublimation Transfers (onto FR-Plastic/Woods) 60-70 seconds
- Step 8: Mouse pads, coasters and other thicker materials may also be pressed. Simply adjust the pressure adjust gear - clockwise to increase pressure, and counterclockwise to decrease pressure.

4. Recommendations:

- 1) Ceramic tile transfer: (Mugs & Plates transfer is similar)
 Set temperature: 180°C.
 Set time: 15 seconds
- 2) T-shirt transfer:
 Set temperature: 180°C.
 Set time: (chemical fiber use for sublimation transfer paper: 30-50seconds; pure cotton use for T-shirt transfer paper: 10-20seconds)

NOTE:

- 1) Please switch off the machine and unplug the power cord when the machine is not in use.
- 2) The heat platen will cool down to the room temperature, if heat press stays unused for more than 30 minutes.
- 3) The heat-releasing fan will automatically starts when the temperature of heat platen reaches 80 degree C (176 degree F). It helps to reduce the temperature of electrical parts and prolong the service life of them.
- 4) For better maintenance of heat press, the maximum setting temperature is 210 degrees C (410 degrees F).
- 5) To avoid re-heating the first transfer when printing double sided T-Shirts, insert a sheet of cardboard in between

the shirt, adjust the height to less pressure, then press.

6) Heat platen may pivot slightly back and forth rotationally. This is due to movement allowance within the clamp assembly, and is normal.

IV. Maintenance

1. No action after turn on the machine

- 1). Check the plug whether it connects well or whether it is broken.
- 2). Check the power switch or temp. & time controller whether it is broken.
- 3). Check the fuse whether it has been burnt out.
- 4). Indicating light is on, but no display on screen, check the 5 cable of Railway transformer. If it's loosening, showing the problem is poor connection. If they connects well, showing that the Transformer is faulty.

2. Turn the power switch on, light is in the bright, the Temperature controller only displays –L-- and no any other changes.

Checking the connection of Thermocouple whether it's loosened. Or the Thermocouple is broken.

3. Turn the power switch on, light is in the bright, the Temperature controller only displays –H-- and no any other changes.

Checking the temperature controller if it's with interior damping, or the controller is broken.

4. Turn the power switch on, light is in the bright, the Temperature controller displays incomplete data.

Checking the nixie tube or the electronic component whether it's damaged.

5. The machine is at state of working: Press the Limit Switch, Time controller shows no countdown.

- 1). Checking the connection of Limit Switch if it's loosened.
- 2). Checking the switch whether it's pressed properly.
- 3). If above steps are good, maybe the Limit Switch is broken.

6. The heat platen is heating well, but the Time Controller countdown even the platen is not pressed down.

Checking the two cables of Limit Switch whether they are connected mistakenly. If the connection is reversed, the problem would exist.

7. The setting temp and time becomes abnormal after exchange the heat platen

- 1). Please reset the temp and time according the operation process manual.

8. Other notice

- 1). In order to prolong the machine service life, please add the lubrication oil regularly on the joints.
- 2). In order to keep the heat platen's good transfer effect, you need to protect the heat platen carefully whenever you are using it or not.
- 3). Please keep the machine in dry place.
- 4). If you are not able to solve the electrical parts problem, please kindly contact the supplier and get technical support

V. Trouble shooting for transfer print quality

1. If the print color is pale: the temperature is too low / the pressure is not correct / or not pressed long enough.
2. If the print color is too brown or the transfer paper is almost burnt: reduce the setting temperature
2. If the print is blurring: too much transfer time causes proliferation.
3. If print color is different/ partial transfer effect is not good enough: the pressure is not enough / or not pressed

long enough / or poor quality transfer paper.

4. If transfer paper stick to the object after transfer: the temperature is too high/ or poor quality printing ink.

VI. Circuit Diagram

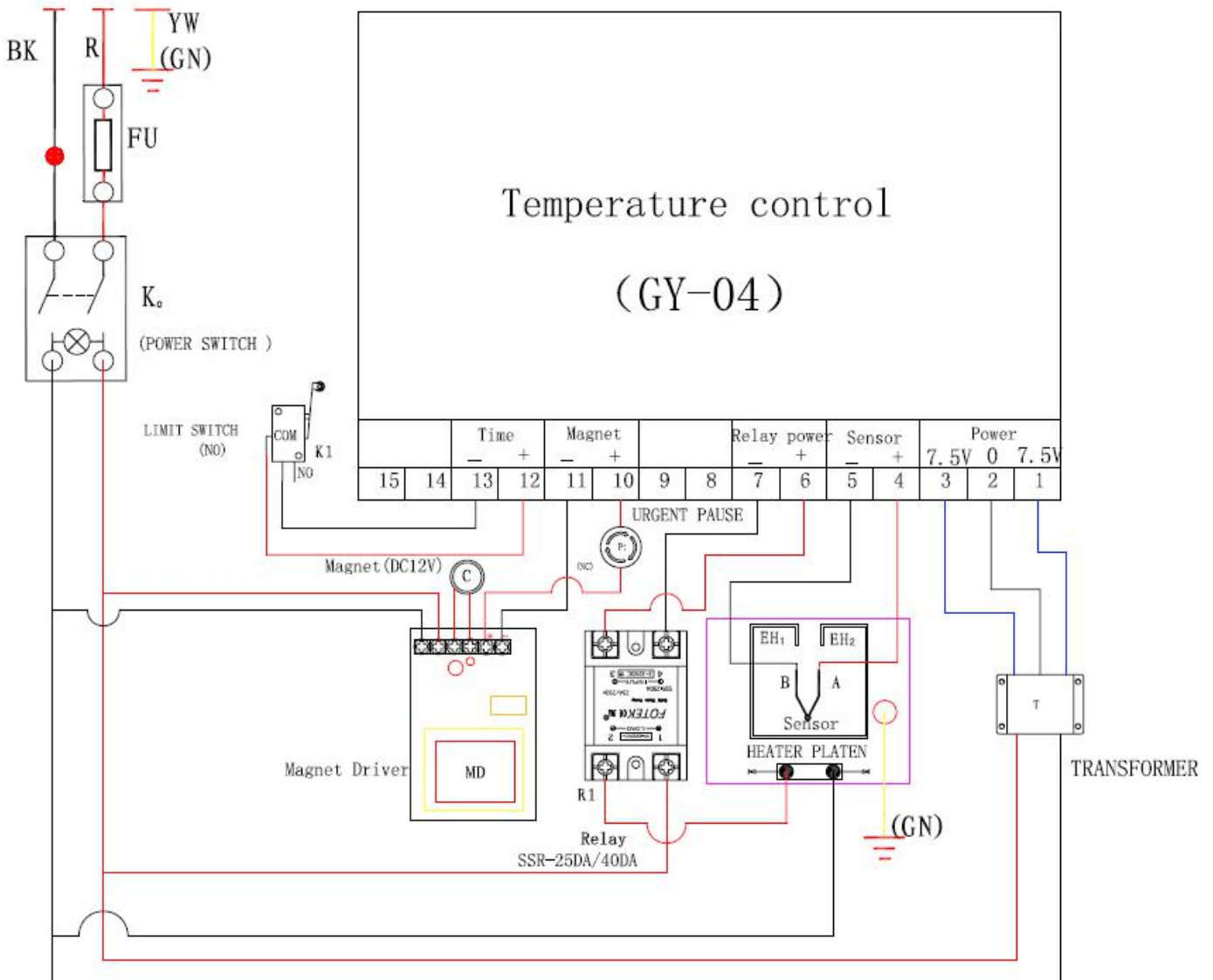

K₀: Power Switch FU:Fuse
 SJ: Digital Controller R1:Relay

T: Transformer EH₁EH₂:Heating Pipe

VII. Explosion View

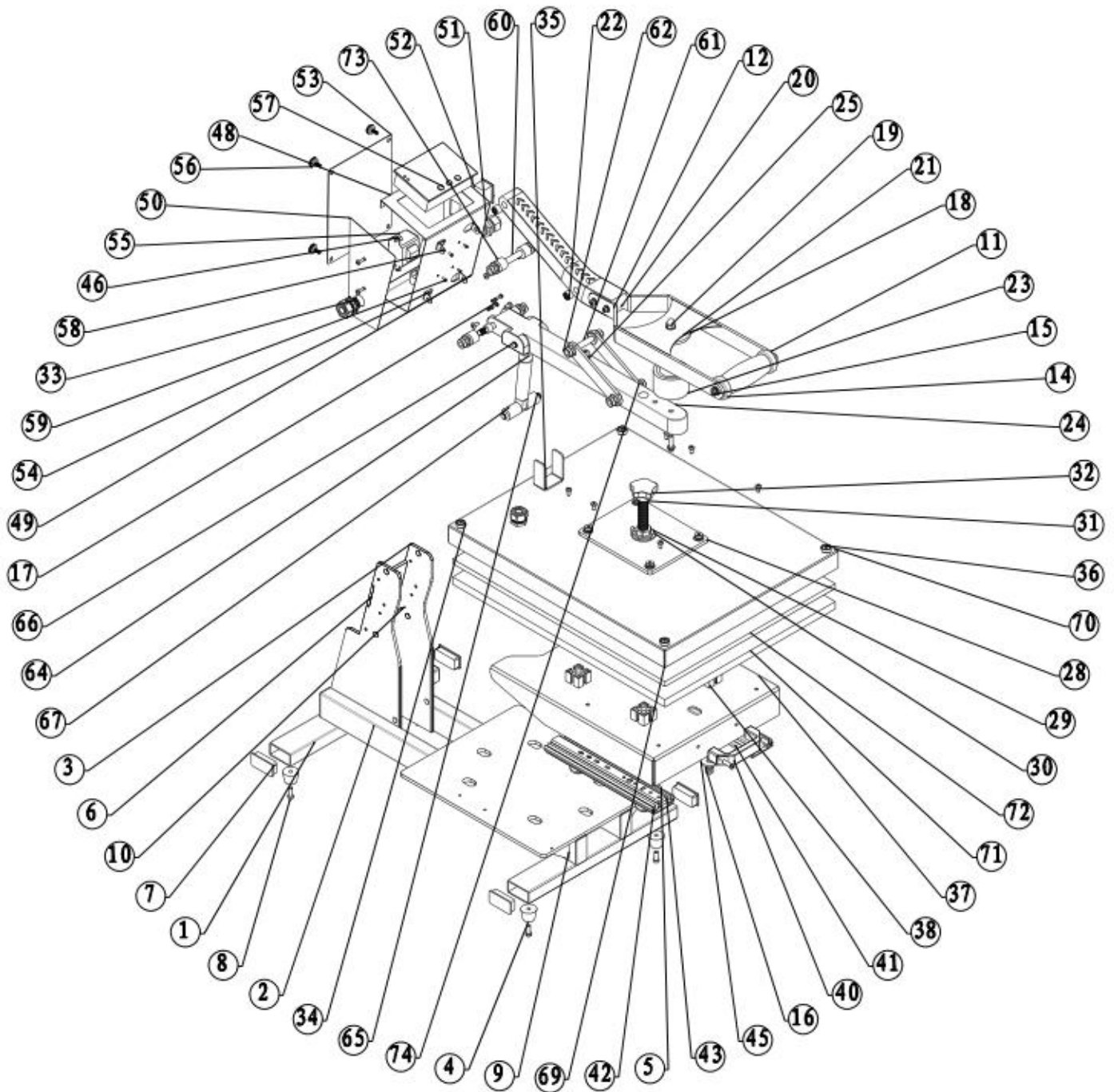

No.	Parts Name	Qty
1	Machine Base 1	2
2	Machine Base 2	2
3	Pillar	2
4	Rubber Foot	4
6	Base Plate	1
7	Strengthen Pillar	1
8	M6 Hexagon Socket Screw	8
9	Strengthen Base Plate	8
10	Limited Switch	4
11	Handle Setting Plate	1
12	Handle Setting Plate	1
13	Handle Spindle	1
14	Eva Handle Bar Grip	1
15	M8 Hexagon Socket Screw	2
16	Play Mat 11*8.5	4
18	Plain Mat 5*3.5	1
19	Electromagnet Cover	1
20	Handle Arm 65*43	1
21	Welding Plate	2
22	TCA1010 Bearing	8
23	Electromagnet	1
24	Handle Arm	1
25	M8 Hex Screw	1
26	38*38 Heat Platen	2
27	38*38 Heat Platen Cover	1
28	Adapter Plate Movable Spindle	1
29	Adjusting Screw Nut	1
30	Plain Mat 43*25	1
31	M16 Adjusting Screw Rod	1
32	M10 Hand Wheel	1
33	Coiler Joint	2
34	Thermal Insulation Baffle	4
35	U Shape Plate	1
36	M6 Flat Head Cross Screws	4
37	Drawer plate	2
38	Under Plate Pillar	4
39	PWB-M3	1
40	Drawer Handle	1
41	Sliding Rod	1
44	PWB-M4	1
45	Plain Mat 28*8.5	2
46	M4 Hex Screw	4
47	Under Plate38*38	4
48	Electric Box Panel	1
49	Electric Box Cover Left	1
50	Electric Box Cover Right	1
51	Joint	1
52	Power Switch	1
53	Electric Box Cover Back	1
54	Solid-state Relay	1
55	Transformer	1
56	Screw with plastic cover	4
57	GY04 controller	1
58	Drive Board	1
59	Cross Screw	4
60	Pillar Pin 5623	2
61	Handle Arm Pin 5623	2
62	M10 Screw	8
63	Piston Rod	1
64	Gas Spring	1
65	Pin	1
66	Spring Fixed End	1
67	Tension spring Hanging Rods544	2
68	Tension spring Hanging Rods543	2
69	Heat Platen 40*50	1
70	Heat Platen Cover 40*50	1
71	Under Plate 40*50	1
72	Silicon Pad 40*50	1
73		4
74	Joint Pin	2