

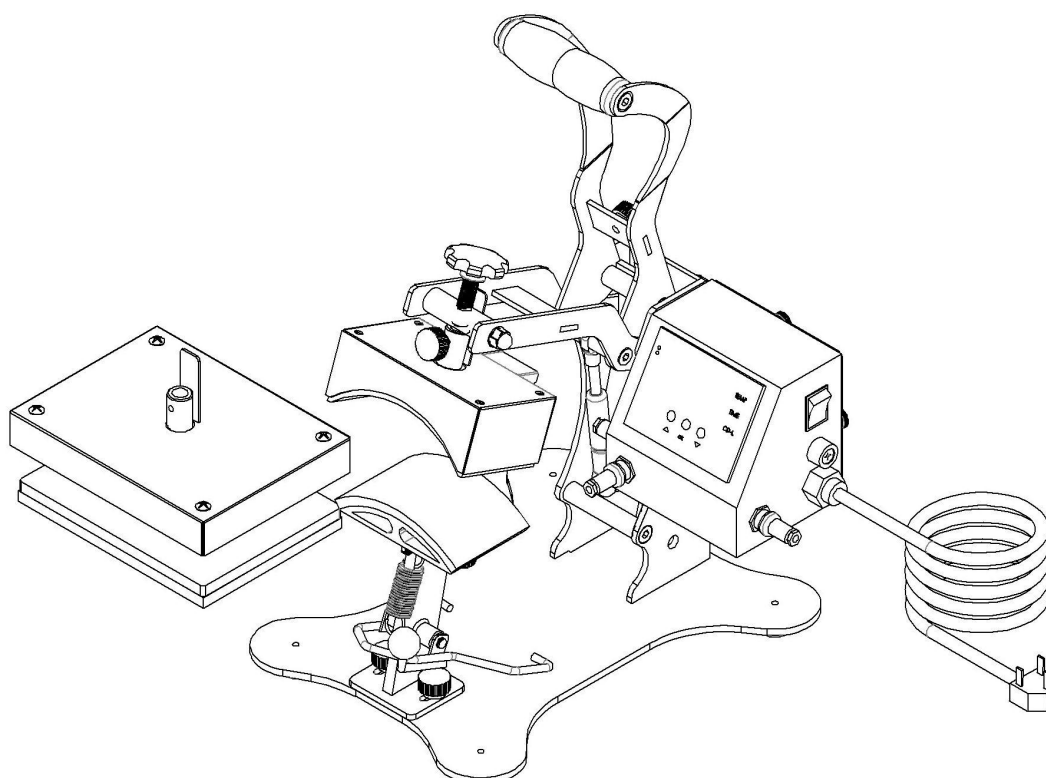

Arkypress Mini 10E / ArkypressDuoCap

Model No.: MEHP-100A/100B/200



CONTENTS

I. Assembly Drawing	-----	2
II. Technical Parameters	-----	4
III. Cap Heater and Plain Heat Platen Exchange	-----	4
IV. Operation Process	-----	5-6
V. Maintenance	-----	7
VI. Trouble Shooting For Transfer Print Quality	-----	7
VII. Circuit Diagram	-----	8
VIII. Explosion View	-----	9



I. Assembly Drawing

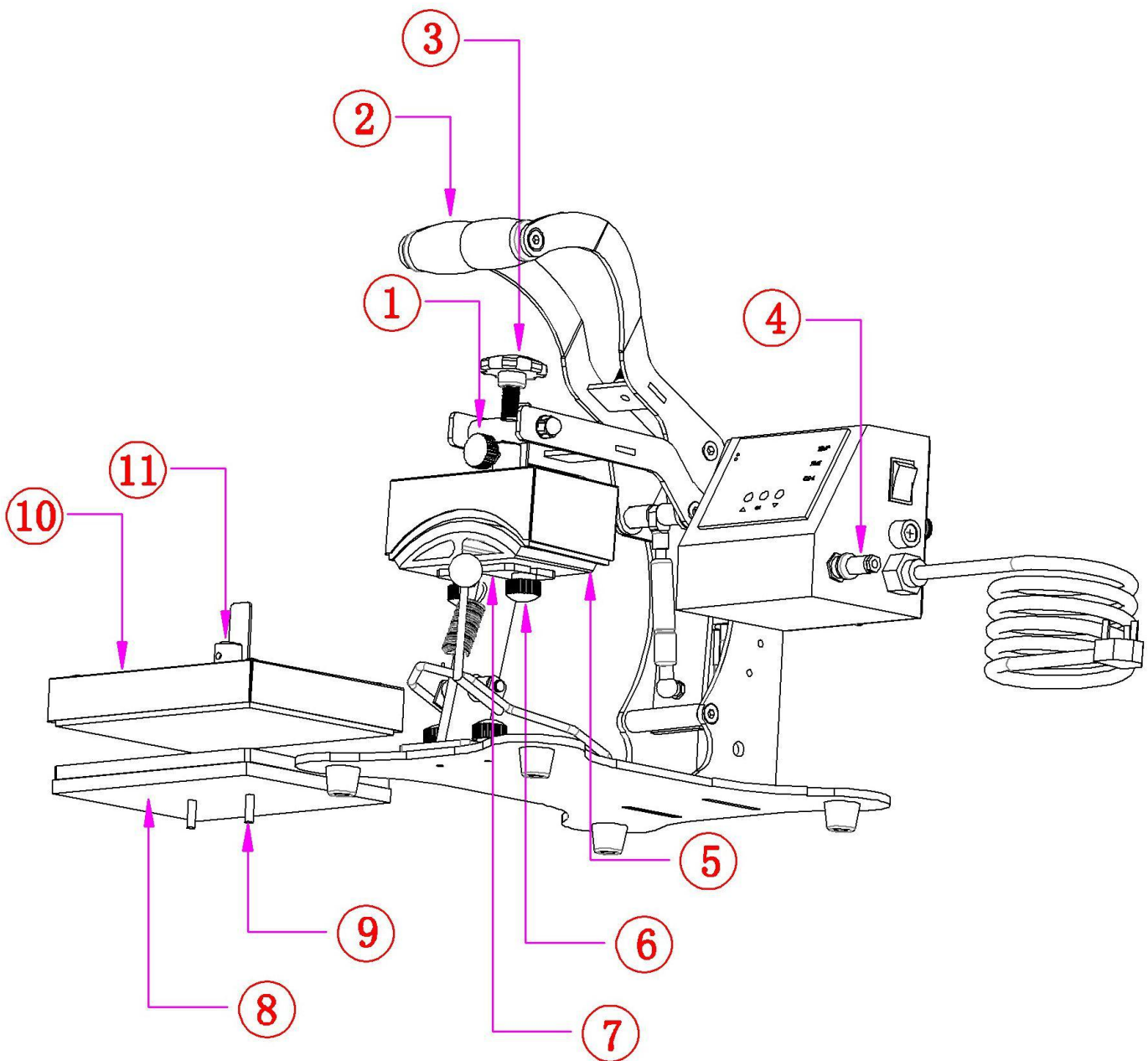

- | | | |
|--------------------------|---------------------|--------------------------|
| ① Upper Hand Wheel Screw | ② Handle Bar Grip | ③ Adjusting Screw |
| ④ Power Cord | ⑤ Cap Heater | ⑥ Under Hand Wheel Screw |
| ⑦ Supporting Holder | ⑧ Plain Under Plate | ⑨ Fasten Screw |
| ⑩ Plain Heat Platen | ⑪ Fixing Fittings | |

II. Technical Parameters

1. Model No.: MEHP-100A/100B/200
2. Machine Dimension: 380*36*340mm
3. Heating Elements Size: one normal cap heater & one 15x 20cm heat platen
4. Printable Articles Max Size: 150 x 80mm&150 x 20mm
5. Voltage: 220V/1Phase
6. Power: 0.5KW for cap press; 0.6KW for heat platen
7. Recommend Setting: 180~190C°; 30~40s.
Time Range: 0~999s
Maximum Temp: 225 C°
8. Packing Size: 48*32*39cm
9. Gross Weight: 19.5kg







III. Cap Heater and Plain Heat Platen Exchange

(Note: Reference picture in Page2)

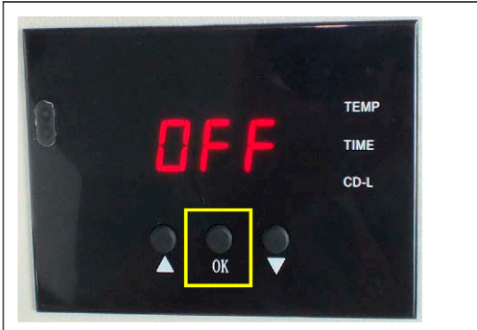
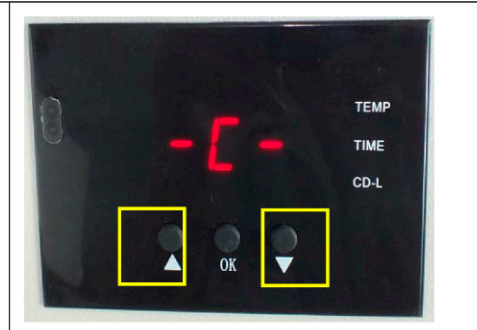
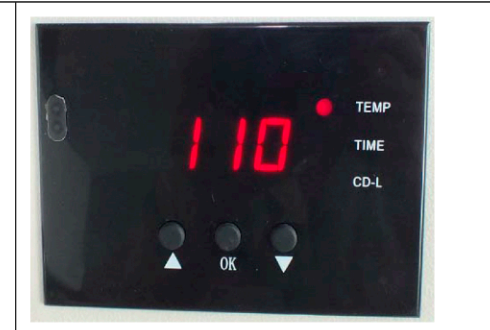





1. Unplug the power socket ④, press down the handle bar grip ② with left hand and release screw bolt ① with right hand.
2. Leave the left hand and the cap platen is now lying on the cap under plate ⑤.
Release screw nut ⑥ to take out the cap press parts.
3. Fix two screws ⑨ in the flat under plate ⑧ and mount it to the support arm ⑦, fasten screw nut ⑥ to fix the flat under plate ⑧.
4. Place flat heat platen ⑩ above the flat under plate ⑧, use left hand to press down the handle bar grip ②, And adjust the heat platen mounts ⑪ and adjustment bolt ③ with right hand, then tighten the screw ①.
5. Use left hand press down the handle bar grip ② again to make sure the flat heat platen ⑩ is aligned with flat under plate ⑧. Fasten the screw bolt ① and screw nut ⑥ tightly and plug the power socket ④.
The exchange process is done.

IV. Operation Process

1. Set temperature required

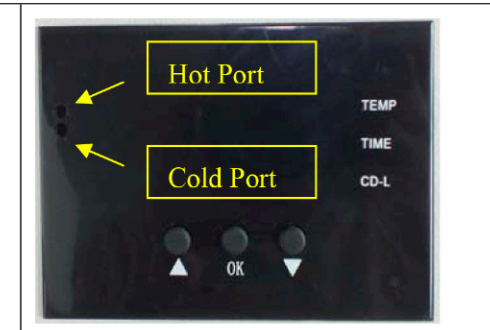
		
<p>Turn on power switch, temperature light is ON. The digital display shows </p>	<p>Press  button, the  light is on (C denotes Celsius). Press arrows “△” or “▽” to select “C” or “F” (F denotes Fahrenheit) according to your habits.</p>	<p>Press  button, the temp  light is on. Select with arrows the temperature according to different transfer material (Normally 180°C~200°C)</p>

2. Set time required

		
<p>Press  button after temperature setting and the  time light is on. Select with arrows the time according to different transfer material.</p>	<p>Press  button after time setting; the display shows the temperature starts to rise. “CD-L” shows the time counting down during your transfer.</p>	<p>Note: There are two small port in front side of the digital display. If the real temperature is lower than digital controller shown, you can adjust the “hot port”; Clockwise to raise temperature; anticlockwise to reduce temperature.</p>

3. Printing methods

Step 1: Make sure the cord is connected well to the wall socket. Place the cap in the cap heater, and transfer paper with images facing down the cap, adjust moderate pressure, and power on.

P.S: use heat resistant tape to fix the transfer paper, make sure transfer paper is exactly attached to cap heater;

Step 2: Set the temperature and time required, then temperature starts to rise.

Step 3: When the temperature rises to the setting temperature, the buzzer sends out sounds; then press down the cap heater, (meantime the sounds stop) and starts to transfer.

Step 4: Then the time counter is on, once time is up, take out the caps. Transfer work finished.

Note: use the similar way when you need to transfer other substrates by using the plain heat platen.

But the printing parameters are different from different items. You can refer to below.

5. Recommendations:

1) Cap transfer:

Set temperature: 180°C.

Set time: 60 seconds

2) Ceramic Tile transfer:

Set temperature: 210°C.

Set time: 240seconds

3) Key Chains & Pearlite Plate transfer:

Set temperature: 180°C.

Set time: 100~120seconds

4) Mirror (Pearlite plate) and Jigsaw Puzzle transfer:

Set temperature: 180°C.

Set time: 60~80seconds

5) Wallet (Waist pack) transfer:

Set temperature: 180°C.

Set time: 120~140seconds

NOTE:

1) Please switch off the machine and unplug the power cord when the machine is not in use.

2) The heater or heat platen will cool down to the room temperature, if heat press stays un-use for more than 30 minutes.

3) For better maintenance of heat press, the maximum setting temperature is 210 degrees C (410 degrees F).

4) To avoid re-heating the first transfer when printing double sided substrates, insert a sheet of cardboard in between the item, adjust the height to less pressure, then press.

5) Heat platen may pivot slightly back and forth rotationally. This is due to movement allowance within the clamp assembly, and is normal.

V. Maintenance

1. No action after turn on the machine

- 1). Check the plug whether it connects well or whether it is broken.
- 2). Check the power switch or digital controller whether it is broken.
- 3). Check the fuse whether it has been burnt out.
- 4). Indicating light is on, but no display on screen, check the 5 cable of Railway transformer. If it's loosening, showing the problem is poor connection. If they connects well, showing that the Transformer is faulty.

2. The display screen are working well, but no temperature increasing on the heating element.

- 1). Check whether the thermocouple of the heating element touches well. If the thermocouple is loose, the display will show 255°C. and machine keeps beeping.
- 2). Check if the indicating light of solid-state relay is on, if not, check if the relay or digital controller is broken.
- 3). If you already changed the new solid-state relay but the heating element still can't heating up, check if the cap heater is faulty or the heating element's power cable is loose, need to change by new heating element.

3. The display screen show 255°C once you power on.

- 1). Check whether the thermocouple is loose or not.
- 2). If the thermocouple touches is not in loose state, but still show 255°C, then it is faulty.

4. The machine is heating during 0~180°C, but display number jumps to above 200°C or 300°C suddenly, or the numbers on display jumps irregularly.

- 1). Check whether the thermocouple of the heating element touches well.
- 2). If the thermocouple is good, It shows that the program of digital controller is broken, which namely IC or is broken, need to change by new controller.

5. The temperature is out of control: Set 180°C, but the actual temperature is above 200°C.

- 1). It means the solid-state relay is broken, out of control, need to change the relay.
- 2). Or the digital controller is faulty and it keeps conveying electric to relay, need to change controller.

6. The setting temp and time becomes abnormal after exchange the heating element.

- 1). Please reset the temp and time according the operation process manual.

7. Other notice

- 1). In order to prolong the machine service life, please add the lubrication oil regularly on the joints.
- 2). In order to keep the cap heater's good transfer effect, pls protect it carefully whenever you are using or not.
- 3). Please keep the machine in dry place.
- 4). If you are not able to solve the electrical parts problem, please kindly contact the supplier and get technical support.

VI. Trouble shooting for transfer print quality

1. If the print color is pale: the temperature is too low / the pressure is not correct / or not pressed long enough.
2. If the print color is too brown or the transfer paper is almost burnt: reduce the setting temperature.
2. If the print is blurring: too much transfer time causes proliferation.
3. If print color is different/ partial transfer effect is not good enough: the pressure is not enough / or not pressed long enough / or poor quality transfer paper.
4. If transfer paper stick to the object after transfer: the temperature is too high/ or poor quality printing ink.

VII. Circuit Diagram

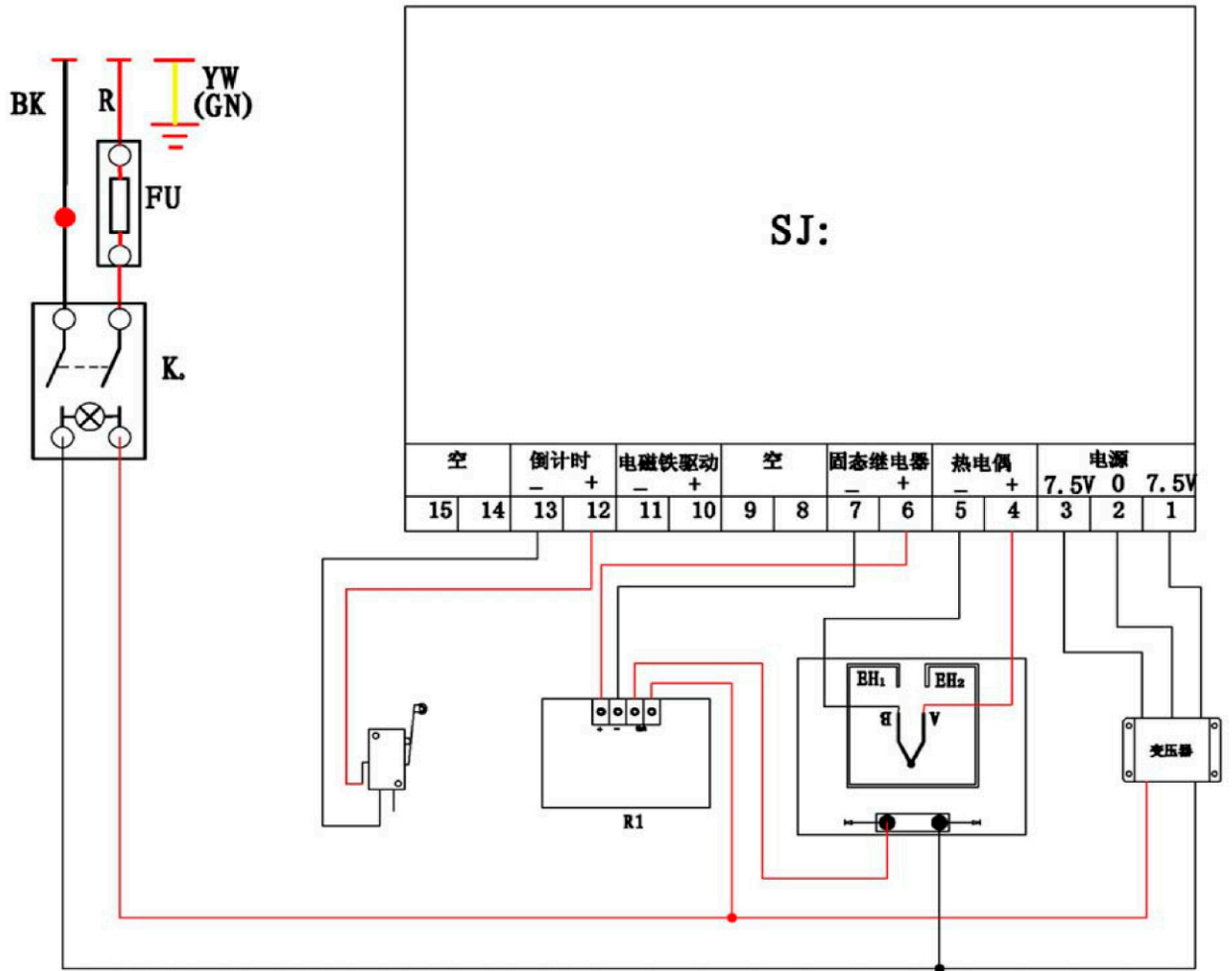

K₀: Power Switch
T: Transformer

SJ: Digital Controller
R1: Relay

FU: Fuse

EH₁EH₂: Heating Pipe

VIII. Explosion View

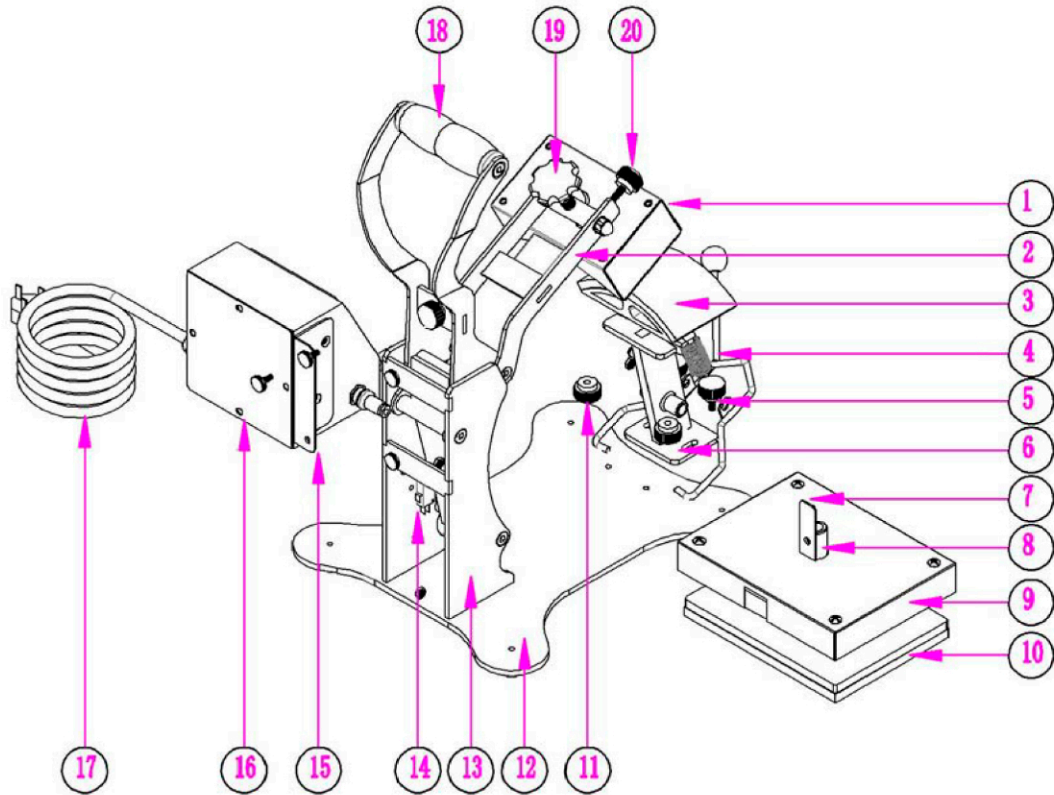

Item	Parts Name	Qty
1	Cap Heater	1 pc
2	Handle Shaft	1 pc
3	Cap Under Plate	1 pc
4	Cap Presser	1 pc
5	Screw	2 pc
6	Supporting Holder	1 pc
7	Anti-swing Part	1 pc
8	Adapter	1 pc
9	Flat Heat Platen	1 pc
10	Flat Under Plate	1 pc

11	Screw	2 pc
12	Machine Base	1 pc
13	Supporting Plate	2 pc
14	Limit Switch	1 pc
15	Electrical Parts Bracket	1 pc
16	Electrical Case	1 pc
17	Power Cord	1 pc
18	Handle Bar Grip	1 pc
19	Pressure Adjusting Screw	1 pc
20	Screw	1 pc